

LIQUID CRYSTAL DISPLAY MODULE

Product Specification

PRODUCT NUMBER	LWD70620EW640G320WID
---------------------------	-----------------------------

INTERNAL APPROVALS	
Engineering	Document Control
<i>Michael Gu</i>	

Product No.	LWD70620EW640G320WID	REV. A
-------------	----------------------	--------

Page	1 / 23
------	--------

TABLE OF CONTENTS

1	MAIN FEATURES.....	4
2	MECHANICAL DRAWING.....	5
3	ABSOLUTE MAXIMUM RATINGS	6
4	ELECTRICAL CHARACTERISTICS.....	7
4.1	OPERATING CONDITIONS	7
4.2	LED DRIVING CONDITIONS	7
5	DC CHARACTERISTICS	8
6	AC CHARACTERISTICS	9
6.1	SYSTEM BUS TIMING FOR 6800 SERIES MPU	9
6.2	SYSTEM BUS TIMING FOR 8080 SERIES MPU	10
6.3	SYSTEM BUS TIMING FOR 4-LINE SERIAL INTERFACE	11
6.4	SYSTEM BUS TIMING FOR 3-LINE SERIAL INTERFACE	12
7	OPTICAL CHARACTERISTICS.....	13
8	INTERFACE PIN ASSIGNMENT.....	15
8.1	BACKLIGHT UNIT SECTION	16
9	BLOCK DIAGRAM.....	17
10	RELIABILITY.....	18
10.1	RELIABILITY TEST	18
11	INITIAL CODE.....	19
12	PART NUMBER LABELLING.....	21
13	PART NUMBER DECODER	22
14	HANDLING PRECAUTIONS.....	23

REVISION RECORD

Rev.	Date	Page	Sec.	Comment	ECN No.
A	03/11/16	--	--	New Densitron Release	E5195

1 MAIN FEATURES

ITEM	DESCRIPTION	UNIT
Display Format	640 x 320	dots
Outline Dimension	170.32 (W) x 88.3 (H) x 5.3 (D)	mm
Viewing Area	141.60 (W) x 73.40 (H)	mm
Active Area	140.00 (W) x 70.00 (H)	mm
LCD Type	TFT / Transmissive / Normally Black	--
Viewing Angle	80/80/80/80	--
Backlight	LED	
Color	White	--
Interface	Parallel/Serial	--
Operating Temperature	-20 ~ 70	°C
Storage Temperature	-30 ~ 80	°C
RoHS Compliant	Yes	--

2 MECHANICAL DRAWING

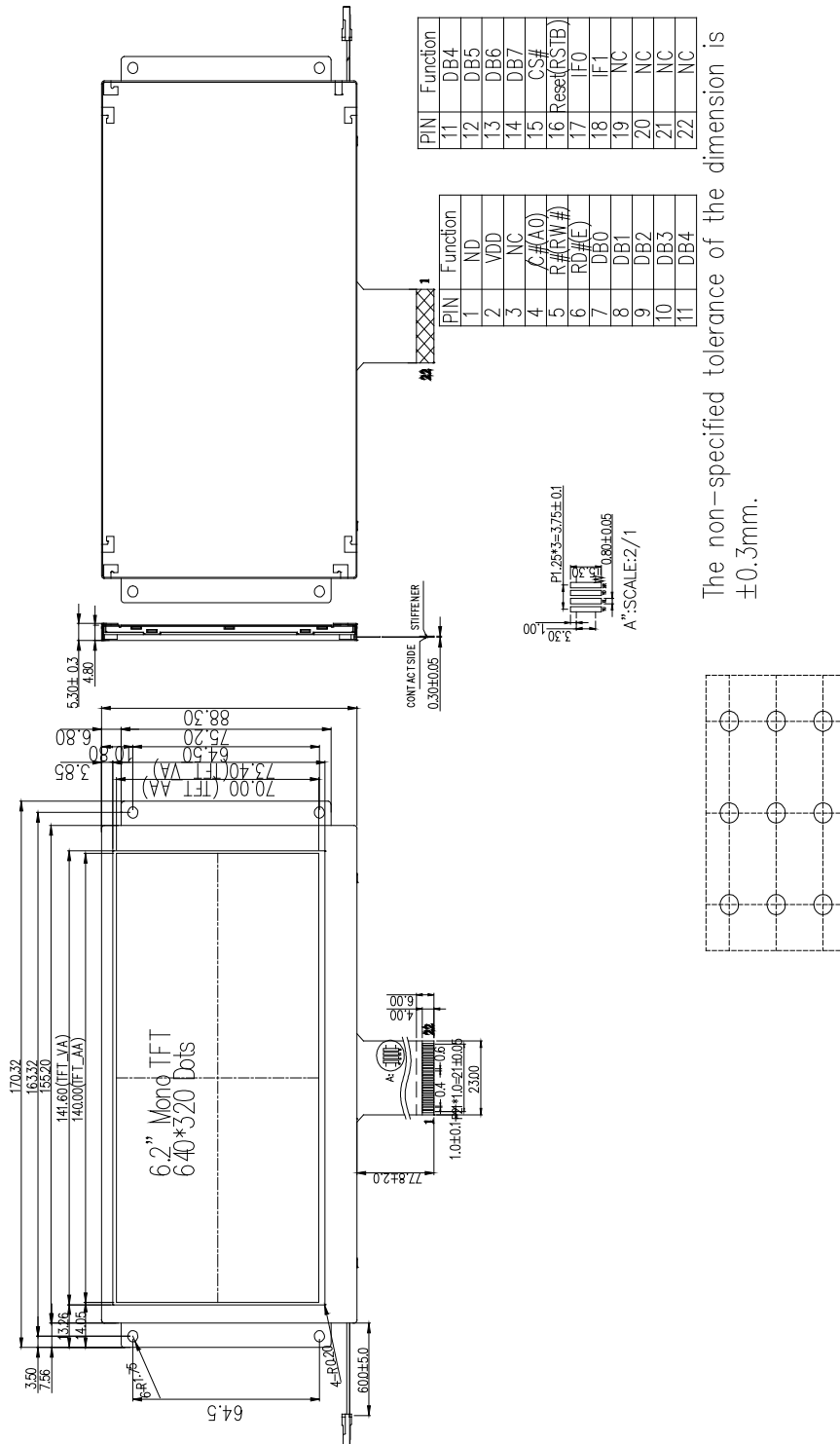

The non-specified tolerance of the dimension is ±0.3mm.

Product No.	LWD70620EW640G320WID	REV. A
-------------	----------------------	--------

Page	5 / 23
------	--------

3 ABSOLUTE MAXIMUM RATINGS

Item	Symbol	Min	Typ	Max	Unit
Operating Temperature	TOP	-20	-	+70	°C
Storage Temperature	TST	-30	-	+80	°C

Note:

1. Device is subject to be damaged permanently if it is stressed beyond the above absolute maximum ratings listed above.
2. Temp. $\leq 60^{\circ}\text{C}$, 90% RH MAX. Temp. $> 60^{\circ}\text{C}$, Absolute humidity shall be less than 90% RH at 60°C

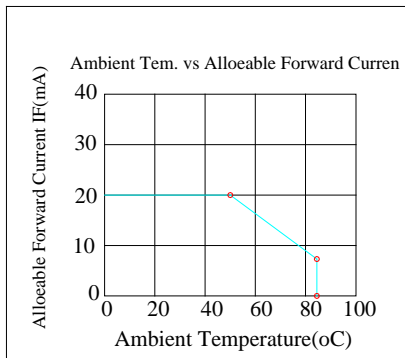

4 ELECTRICAL CHARACTERISTICS

4.1 OPERATING CONDITIONS

Item	Symbol	Condition	Min	Typ	Max	Unit	Remark
Supply Voltage For LCM	VDD	-	3.0	3.3	3.6	V	
Supply Current For LCM	IDD	-	-	25	38	mA	Note1
Power Consumption	-	-	-	83	137	mW	

Note:

1. This value test is for VDD = 3.3V only.

4.2 LED DRIVING CONDITIONS

Parameter	Symbol	Min.	Typ.	Max.	Unit	Remark
LED current		-	160	-	mA	
Power Consumption		1392	-	1680	mW	
LED voltage	VLED+	8.7	9.6	10.5	V	Note 1
LED Life Time		-	20,000	-	Hr	Note 2,3,4

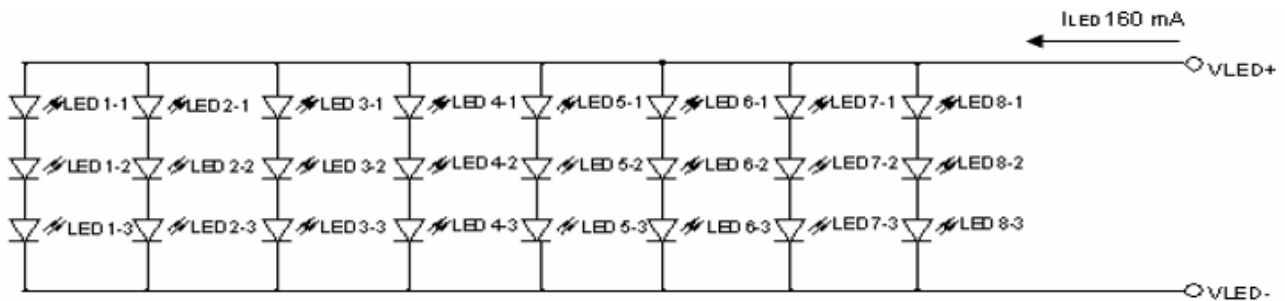

Note:

1. Power supplied to the backlight specification.
2. Ta = 25°C
3. Brightness to be decreased to 50% of the initial value.
4. Single LED lamp case.

Product No.	LWD70620EW640G320WID	REV. A
-------------	----------------------	--------

Page	7 / 23
------	--------

5 DC CHARACTERISTICS

Parameter	Symbol	Rating			Unit	Condition
		Min	Typ	Max		
Low level input voltage	V_{IL}	0	-	0.3VDD	V	
High level input voltage	V_{IH}	0.7VDD	-	VDD	V	

6 AC CHARACTERISTICS

6.1 SYSTEM BUS TIMING FOR 6800 SERIES MPU

System Bus Timing for 6800 Series MPU

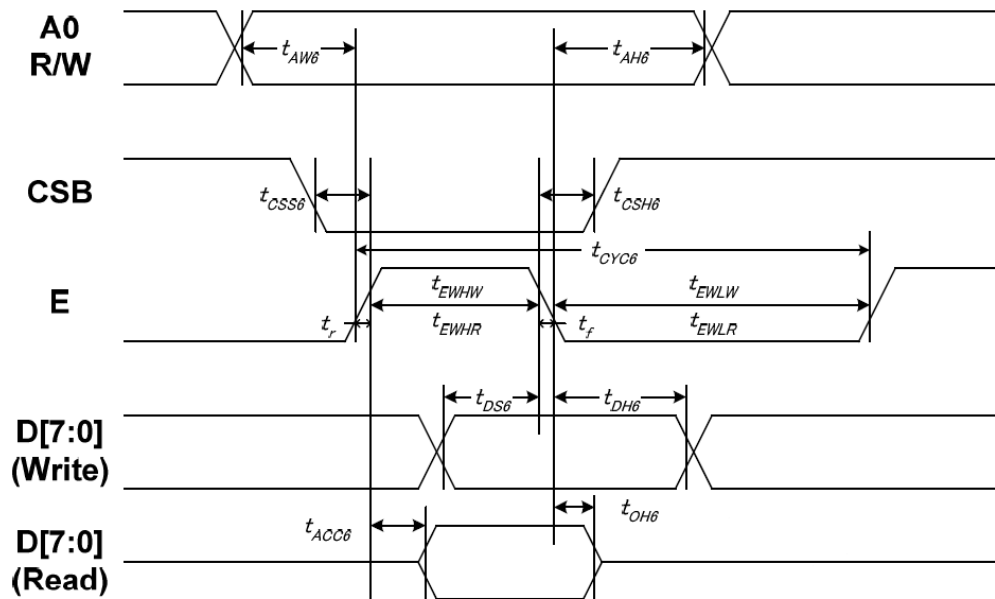

Item	Signal	Symbol	Condition	Min	Max	Unit
Address setup time	A0	tAW6	-	10	-	ns
Address hold time		tAH6	-	0	-	
System cycle time	E	tCYC6	-	200	-	
Enable L pulse width (WRITE)		tEHLW	-	100	-	
Enable H pulse width (WRITE)		tEHWLW	-	100	-	
Enable L pulse width (READ)		tEHLR	-	130	-	
Enable H pulse width (READ)	tEWHR	-	130	-		
CSB setup time	CSB	tCSS6	-	100	-	
CSB hold time		tCSH6	-	100	-	
Write data setup time	D[7:0]	tDS6	-	70	-	
Write data hold time		tDH6	-	20	-	
Read data access time		tACC6	CL = 100 pF	-	80	
Read data output disable time		tOH6	CL = 100 pF	15	80	

Note:

1. The input signal rise time and fall time (t_r , t_f) is specified at 15 ns or less. When the system cycle time is extremely fast, $(t_r + t_f) \leq (t_{CYC8} - t_{CCLW} - t_{CCHW})$ for $(t_r + t_f) \leq (t_{CYC8} - t_{CCLR} - t_{CCHR})$ are specified.

2. All timing is specified using 20% and 80% of VDDI as the reference.

3. t_{CCLW} and t_{CCLR} are specified as the overlap between CSB being "L" and /WR and /RD being at the "L" level. CSB and /WR (or /RD) cannot act at the same time and CSB should be 100ns wider than /WR (or /RD).

6.2 SYSTEM BUS TIMING FOR 8080 SERIES MPU

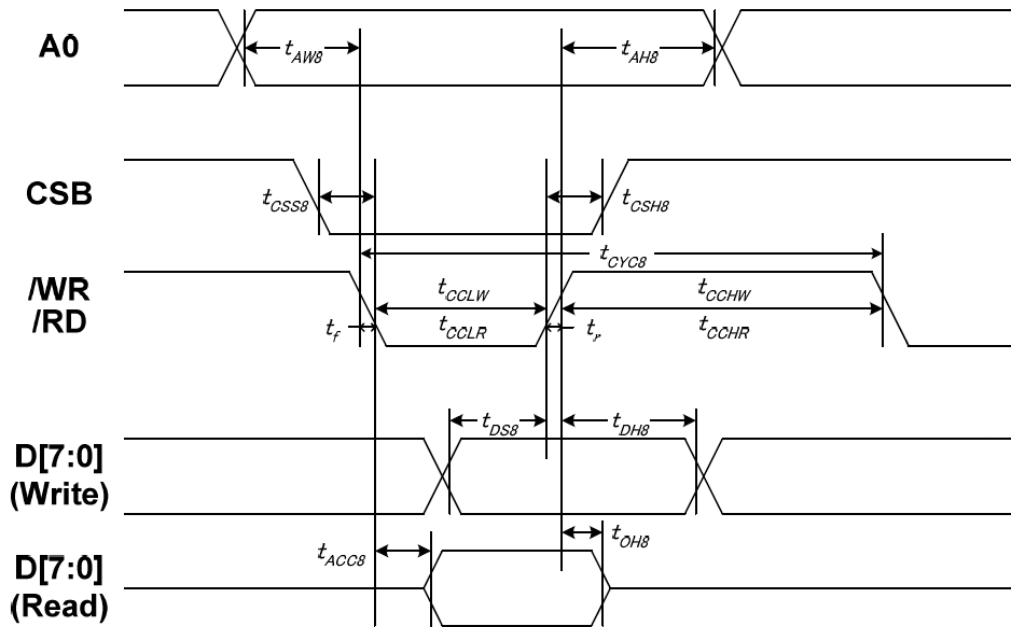

Item	Signal	Symbol	Condition	Min	Max	Unit
Address setup time	A0	tAW8	-	10	-	ns
Address hold time		tAH8	-	0	-	
System cycle time	/WR	tCYC8	-	200	-	
/WR L pulse width (WRITE)		tCCLW	-	100	-	
/WR H pulse width (WRITE)		tCCHW	-	100	-	
/RD L pulse width (READ)		/RD	tCCLR	-	120	
/RD H pulse width (READ)	tCCHR		-	120	-	
CSB setup time	CSB	tCSS8	-	100	-	
CSB hold time		tCSH8	-	100	-	
Write data setup time	D[7:0]	tDS8	-	70	-	
Write data hold time		tDH8	-	20	-	
Read data access time		tACC8	CL = 100 pF	-	80	
Read data output disable time		tOH8	CL = 100 pF	15	80	

Note:

1. The input signal rise time and fall time (t_r , t_f) is specified at 15 ns or less. When the system cycle time is extremely fast, $(t_r + t_f) \leq (t_{CYC8} - t_{CCLW} - t_{CCHW})$ for $(t_r + t_f) \leq (t_{CYC8} - t_{CCLR} - t_{CCHR})$ are specified.

2. All timing is specified using 20% and 80% of VDDI as the reference.

3. tCCLW and tCCLR are specified as the overlap between CSB being "L" and /WR and /RD being at the "L" level. CSB and /WR (or /RD) cannot act at the same time and CSB should be 100ns wider than /WR (or /RD).

6.3 SYSTEM BUS TIMING FOR 4-LINE SERIAL INTERFACE

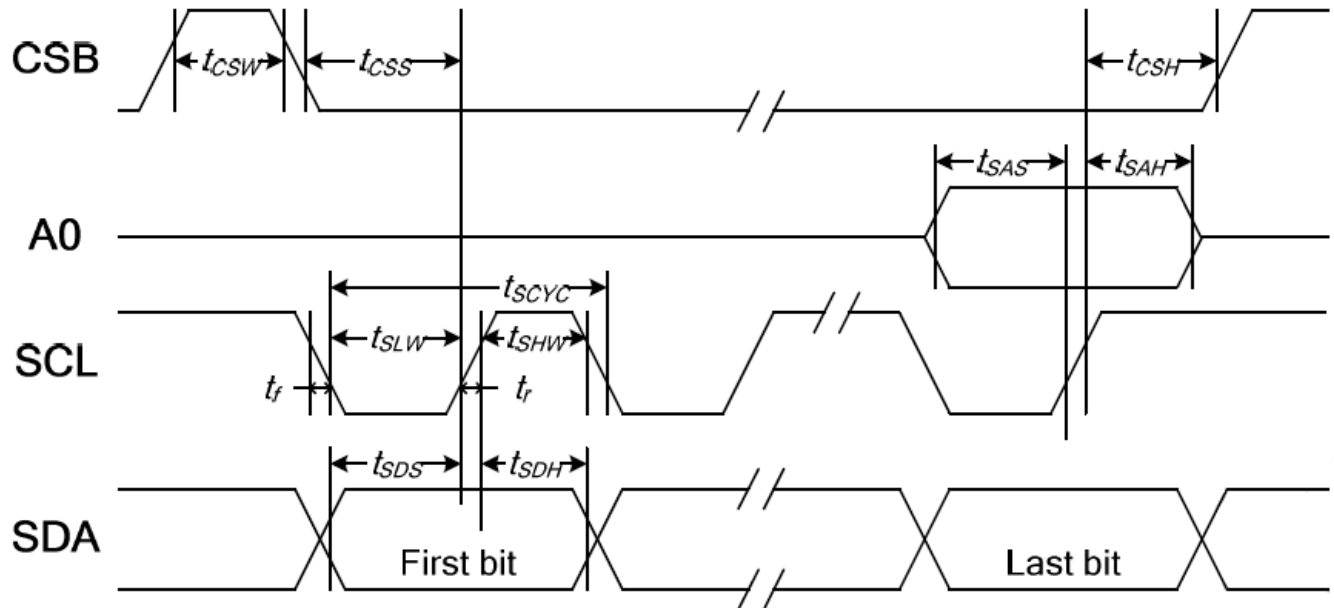

Item	Signal	Symbol	Condition	Min	Max	Unit
Serial clock period	SCL	tSCYC	-	80	-	ns
SCL "H" pulse width		tSHW	-	40	-	
SCL "L" pulse width		tSLW	-	40	-	
Address setup time	A0	tSAS	-	40	-	
Address hold time		tSAH	-	40	-	
Data setup time	SDA	tSDS	-	15	-	
Data hold time		tSDH	-	20	-	
CSB-SCL time	CSB	tCSS	-	40	-	
CSB-SCL time		tCSH	-	40	-	
CSB "H" pulse width		tCSW	-	15	-	

Note:

1. The input signal rise and fall time (t_r , t_f) are specified at 15 ns or less.
2. All timing is specified using 20% and 80% of VDDI as the standard.

6.4 SYSTEM BUS TIMING FOR 3-LINE SERIAL INTERFACE

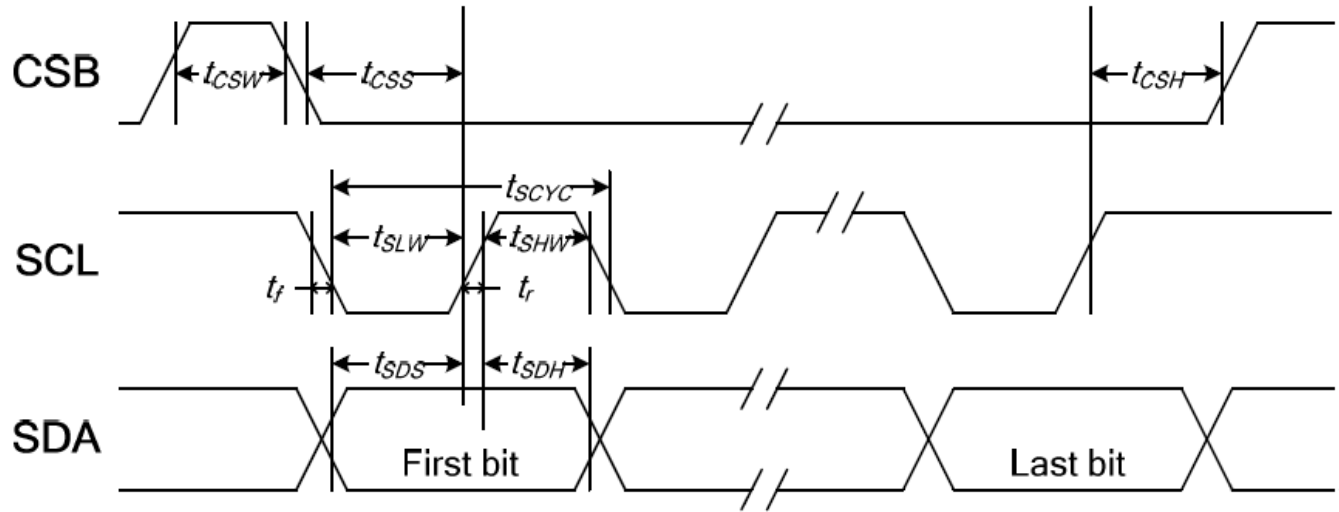

Item	Signal	Symbol	Condition	Min	Max	Unit
Serial clock period	SCL	tSCYC	-	80	-	ns
SCL "H" pulse width		tSHW	-	40	-	
SCL "L" pulse width		tSLW	-	40	-	
Data setup time	SDA	tSDS	-	15	-	
Data hold time		tSDH	-	20	-	
CSB-SCL time	CSB	tCSS	-	40	-	
CSB-SCL time		tCSH	-	40	-	
CSB "H" pulse width		tCSW	-	15	-	

Note:

1. The input signal rise and fall time (t_r , t_f) are specified at 15 ns or less.
2. All timing is specified using 20% and 80% of VDDI as the standard.

7 OPTICAL CHARACTERISTICS

Item	Symbol	Temp	Condition.	Min	Typ.	Max.	Unit	Remark
Response time	Tr	25°C	$\theta=0^\circ, \Phi=0$	-	8	-	.ms	Note 3
	Tf	25°C		-	12	-		
Contrast ratio	CR	25°C	At optimized viewing angle	-	800	-	-	Note 4
Viewing angle (Gray Scale Inversion Direction)	Hor.	Θ_R	25°C	CR \square 10	80		Deg.	Note 1 Note 2
		Θ_L	25°C		80			
	Ver.	Φ_B	25°C		80			
		Φ_T	25°C		80			
Brightness	-	25°C	-	500	600	-	cd/m ²	Center of display

Ta=25±2°C, IL=160mA

1. Definition of viewing angle range

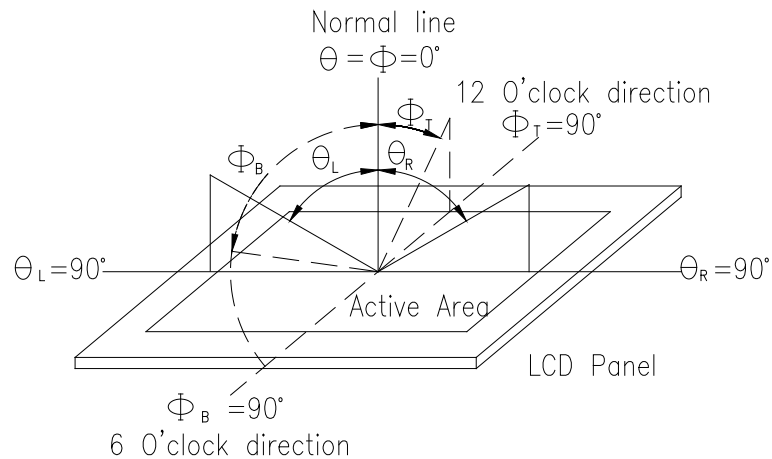

2. Test equipment setup: After stabilizing and leaving the panel alone at a driven temperature for 10 minutes, the measurement should be executed. Measurement should be executed in a stable, windless, and dark room. Optical specifications are measured by Topcon BM-7(BM-5) luminance meter 1.0° field of view at a distance of 50cm and normal direction.

3. Definition of Response time:

The response time is defined as the LCD optical switching time interval between “White” state and “Black” state. Rise time, T_r , is the time between photo detector output intensity changed from 90% to 10%. And fall time, T_f , is the time between photo detector output intensity changed from 10% to 90%

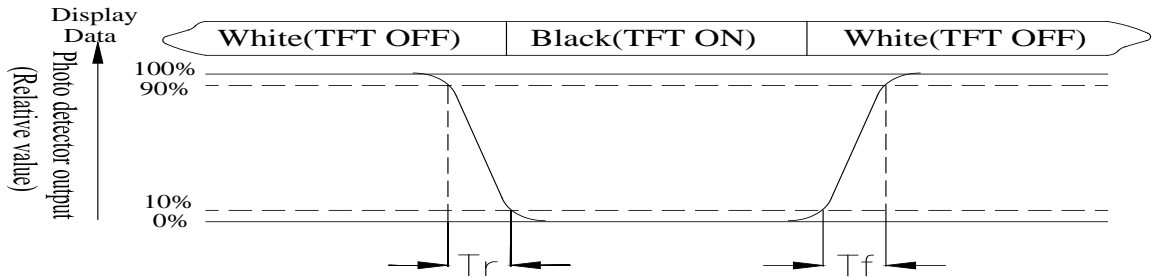

4. Definition of contrast ratio:

The contrast ratio is defined as the following expression.

$$\text{Contrast ratio (CR)} = \frac{\text{Luminance measured when LCD on the "White" state}}{\text{Luminance measured when LCD on the "Black" state}}$$

5. White $V_i = V_{i50} \pm 1.5V$

Black $V_i = V_{i50} \pm 2.0V$

“±” means that the analog input signal swings in phase with VCOM signal.

“±” means that the analog input signal swings out of phase with VCOM signal.

The 100% transmission is defined as the transmission of LCD panel when all the input terminals of module are electrically opened.

6. Measured at the center area of the panel when all the input terminals of LCD panel are electrically opened.

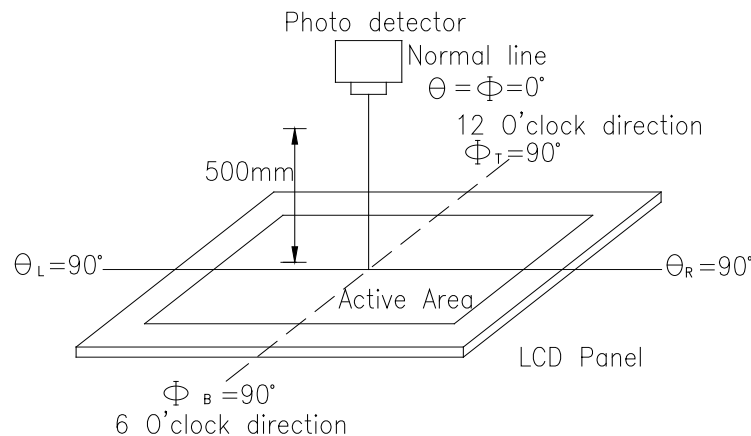

8 INTERFACE PIN ASSIGNMENT

Pin	Symbol	Function	Remark
1	GND	System ground	
2	VDD	Power Supply : +3.3V	
3	NC	No connect	
4	A0	Data/Command select	
5	/WR(R/W)	Write strobe signal	
6	/RD(E)	Read strobe signal	
7	DB0	Data bus	
8	DB1	Data bus	
9	DB2	Data bus	
10	DB3	Data bus	
11	DB4	Data bus	
12	DB5	Data bus	
13	DB6	Data bus	
14	DB7	Data bus	
15	/CS	Chip select	
16	/RESET(RSTB)	Hardware reset	
17	IF0	Mode select	Note1
18	IF1		
19	NC	No connect	
20	NC	No connect	
21	NC	No connect	
22	NC	No connect	

Note:

1.

Setting		MCU Type	Interface Pin Function				
IF1	IF0		CSB	A0	RWR	ERD	D[7:0]
L	L	Parallel 8080 series MCU	CSB	A0	/WR	/RD	D[7:0]
L	H	Parallel 6800 series MCU			R/W	E	D[7:0]
H	H	Serial 4-Line series MCU		-	-	D7=SCL, D0=SDA, D[6:1] are not used	
H	L	Serial 3-Line series MCU		-	-		

The un-used pins are marked as “-” and should be connected to “H” by VDDI.

8.1 BACKLIGHT UNIT SECTION

LED Light Bar connector is used for the the integral backlight system. The recommended model is “JST XH-3” manufactured by JST.

Pin No.	Symbol	I/O	Function	Remark
1	V _{LED+}	P	Power for LED backlight anode (A)	Red
3	V _{LED-}	P	Power for LED backlight cathode (K)	Black

9 BLOCK DIAGRAM

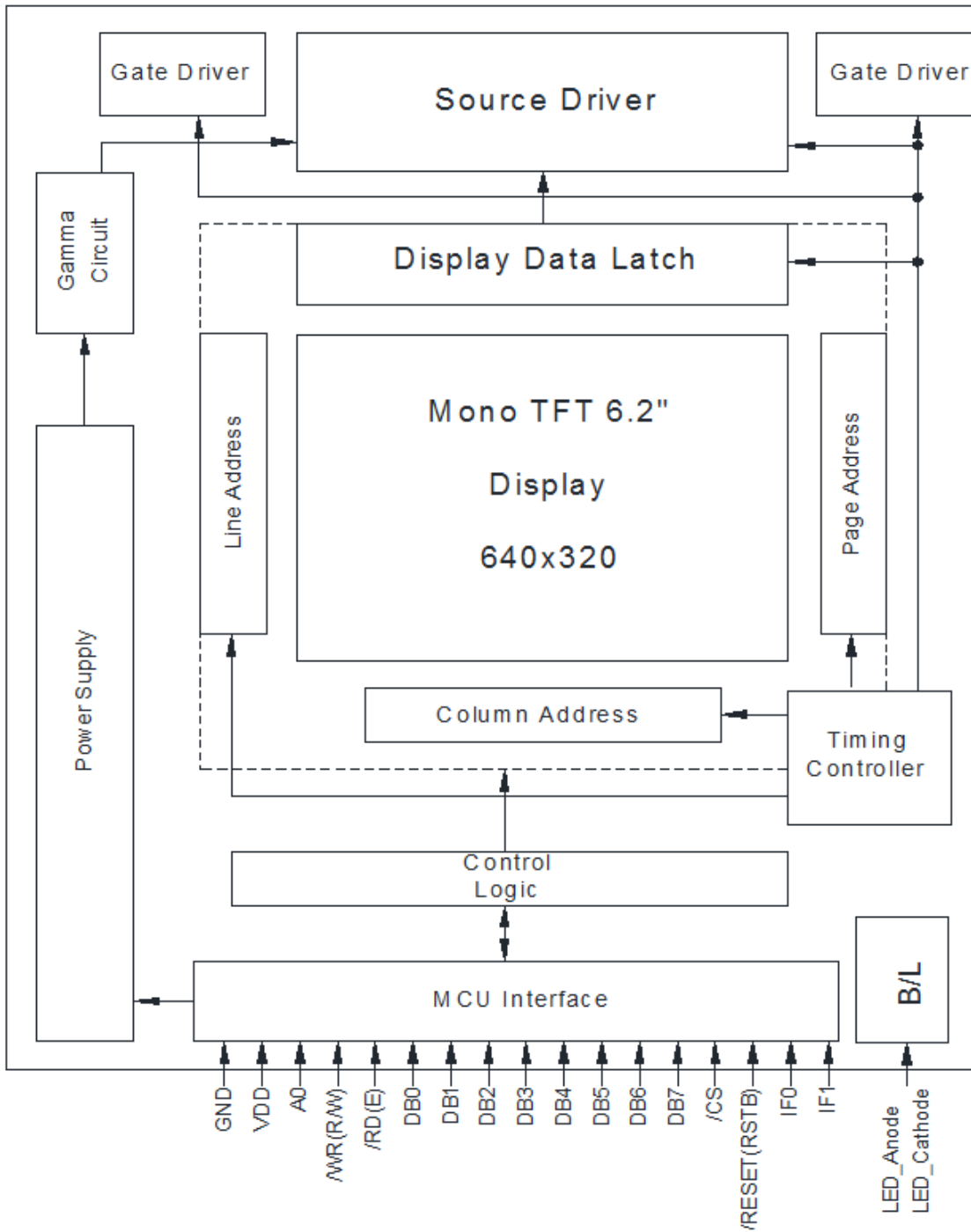

10 RELIABILITY

10.1 RELIABILITY TEST

Content of Reliability Test (Wide temperature, -30°C ~ 80°C)

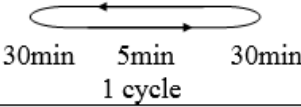
Environmental Test			
Test Item	Content of Test	Test Condition	Note
High Temperature storage	Endurance test applying the high storage temperature for a long time.	80°C 200hrs	2
Low Temperature storage	Endurance test applying the low storage temperature for a long time.	-30°C 200hrs	1,2
High Temperature Operation	Endurance test applying the electric stress (Voltage & Current) and the thermal stress to the element for a long time.	70°C 200hrs	—
Low Temperature Operation	Endurance test applying the electric stress under low temperature for a long time.	-20°C 200hrs	1
High Temperature/ Humidity Operation	The module should be allowed to stand at 60°C, 90%RH max	60°C, 90%RH 96hrs	1,2
Thermal shock resistance	The sample should be allowed stand the following 10 cycles of operation <div style="text-align: center;">  <p style="margin: 0;">-20°C 25°C 70°C</p> <p style="margin: 0;">30min 5min 30min</p> <p style="margin: 0;">1 cycle</p> </div>	-20°C/70°C 10 cycles	—
Vibration test	Endurance test applying the vibration during transportation and using.	Total fixed amplitude : 15mm Vibration Frequency : 10~55Hz One cycle 60 seconds to 3 directions of X, Y, Z for Each 15 minutes	3
Static electricity test	Endurance test applying the electric stress to the terminal.	VS=±600V(contact), ±800v(air), RS=330Ω CS=150pF 10 times	—

Note:

1. No dew condensation to be observed.
2. The function test shall be conducted after 4 hours of storage at the normal temperature and humidity after removing from the test chamber
3. The packing must include the vibration test.

11 INITIAL CODE

```
void Initial_code()
{
    Write_Command(0xae);
    Write_Data(0xa5);
    Write_Command(0x61);
    Write_Data(0x0f);
    Write_Data(0x04);
    Write_Data(0xa5);
    Write_Data(0xa5);

    Write_Command(0x62);
    Write_Data(0x00);
    Write_Data(0x3b);
    Write_Data(0x1b);
    Write_Data(0xa5);

    Write_Command(0x63);
    Write_Data(0x05);
    Write_Data(0x0f);
    Write_Data(0xa5);
    Write_Data(0xa5);

    Write_Command(0x24);
    Write_Data(0x01);
    Write_Data(0xa5);
    Write_Data(0xa5);
    Write_Data(0xa5);

    Write_Command(0x22);
    Write_Data(0x02);
    Write_Data(0xa5);
    Write_Data(0xa5);
    Write_Data(0xa5);

    Write_Command(0x91);
    Write_Data(0x00);
    Write_Data(0x21);
    Write_Data(0x23);
    Write_Data(0x24);

    Write_Command(0x92);
    Write_Data(0x27);
    Write_Data(0x28);
    Write_Data(0x29);
}
```

```
Write_Data(0x2a);  
  
Write_Command(0x93);  
Write_Data(0x2b);  
Write_Data(0x2c);  
Write_Data(0x2d);  
Write_Data(0x2e);  
  
Write_Command(0x94);  
Write_Data(0x30);  
Write_Data(0x31);  
Write_Data(0x32);  
Write_Data(0x3f);  
  
Write_Command(0x99);  
Write_Data(0x00);  
Write_Data(0x21);  
Write_Data(0x23);  
Write_Data(0x26);  
  
Write_Command(0x9a);  
Write_Data(0x27);  
Write_Data(0x28);  
Write_Data(0x29);  
Write_Data(0x2a);  
  
Write_Command(0x9b);  
Write_Data(0x2b);  
Write_Data(0x2c);  
Write_Data(0x2d);  
Write_Data(0x2e);  
  
Write_Command(0x9c);  
Write_Data(0x30);  
Write_Data(0x35);  
Write_Data(0x3b);  
Write_Data(0x3f);  
  
Write_Command(0x12);  
Write_Data(0xa5);  
  
Write_Command(0x15);  
Write_Data(0xa5);  
  
}
```

Product No.	LWD70620EW640G320WID	REV. A
-------------	----------------------	--------

Page	20 / 23
------	---------

12 PART NUMBER LABELLING

All parts will be labelled with the below Part Number.

DENSITRON LWD70620EW640G320WID Rev X TAIWAN YYMM
--

** where "Rev X" denotes the current Revision and YY and MM the 2-digit Year and Month of manufacture*

Product No.	LWD70620EW640G320WID	REV. A
-------------	----------------------	--------

Page	21 / 23
------	---------

13 PART NUMBER DECODER

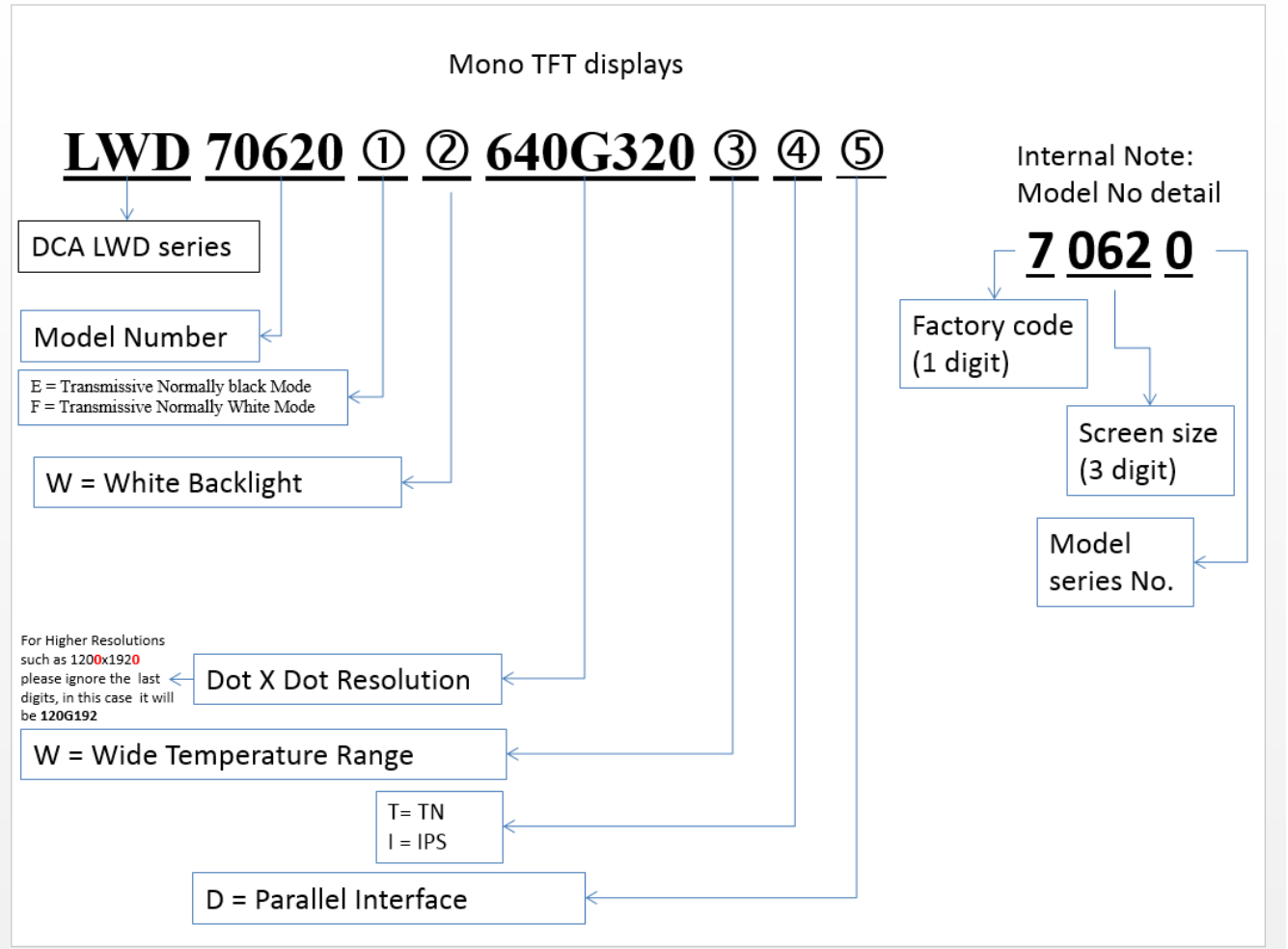

Product No.	LWD70620EW640G320WID	REV. A
-------------	----------------------	--------

Page	22 / 23
------	---------

14 HANDLING PRECAUTIONS

Safety

If the LCD panel breaks, be careful not to get the liquid crystal fluid in your mouth or in your eyes.
If the liquid crystal touches your skin or clothes, wash it off immediately using soap and plenty of water.

Mounting and Design

Place a transparent plate (e.g. acrylic, polycarbonate or glass) on the display surface to protect the display from external pressure. Leave a small gap between the transparent plate and the display surface.
When assembling with a zebra connector, clean the surface of the pads with alcohol and keep the surrounding air very clean. Design the system so that no input signal is given unless the power supply voltage is applied.

Caution during LCD Cleaning

Lightly wipe the display surface with a soft cloth soaked with Isopropyl alcohol, Ethyl alcohol or Trichlorotrifluoroethane. Do not wipe the display surface with dry or hard materials that will damage the polarizer surface. Do not use aromatic solvents (toluene and xylene), or ketonic solvents (ketone and acetone).

Caution against Static Charge

As the display uses C-MOS LSI drivers, connect any unused input terminals to VDD or VSS. Do not input any signals before power is turned on. Also, ground your body, work / assembly table and assembly equipment to protect against static electricity.

Packaging

Displays use LCD elements, and must be treated as such. Avoid strong shock and drop from a height.
To prevent displays from degradation, do not operate or store them exposed directly to sunlight or high temperature / humidity.

Caution during Operation

It is indispensable to drive the display within the specified voltage limit since excessive voltage shortens its life. Direct current causes an electrochemical reaction with remarkable deterioration of the display quality. Give careful consideration to prevent direct current during ON/OFF timing and during operation.
Response time is extremely delayed at temperatures lower than the operating temperature range while, at high temperatures, displays become dark. However, this phenomenon is reversible and does not mean a malfunction or a display that has been permanently damaged. If the display area is pushed on hard during operation, some graphics will be abnormally displayed but returns to a normal condition after turning off the display once. Even a small amount of condensation on the contact pads (terminals) can cause an electro-chemical reaction which causes missing rows and columns. Give careful attention to avoid condensation.

Storage

Store the display in a dark place where the temperature is $25^{\circ}\text{C} \pm 10^{\circ}\text{C}$ and the humidity below 50% RH.
Store the display in a clean environment, free from dust, organic solvents and corrosive gases.
Do not crash, shake or jolt the display (including accessories).

Product No.	LWD70620EW640G320WID	REV. A
-------------	----------------------	--------

Page	23 / 23
------	---------